

Manual cleaning magnetic dirt separator

© Copyright 2018 Caleffi

Code 579001

INSTALLATION AND COMMISSIONING MANUAL



Operating principle

The manual cleaning dirt separator is used in central heating systems to remove dirt and impurities from the circuit, progressively and completely.

The device operates through the continuous action of special filtering elements, located in a chamber through which the system water flows. The very fine filter mesh progressively intercepts particles down to 2 µm in diameter. At the same time, ferrous particles are separated out by magnets on the surface of the filter element.

Cleaning of the filtering elements takes place mechanically, with manual action, by means of the handwheel provided and washing with pressurised mains water while the filtering elements rotate.

CONTENTS

Product range	
Characteristic components	
Package content	2
Technical specifications	
Sizing	
Operating principle	3
Intended use	
Packing, handling, transport	6
Installation	7
Cleaning	
Maintenance	8
Use of additives	9
Commissioning	10
Spare parts	11
Maintenance tasks table	12

Product range

Code 579001 manual cleaning magnetic dirt separator _____ Size DN 50 (2")

Characteristic components

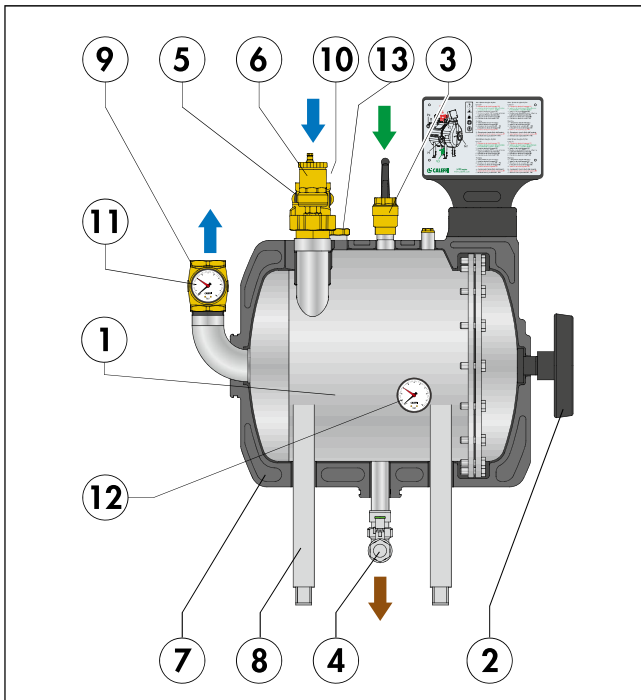

- 1) Filtering unit with magnets
- 2) Handwheel for manual cleaning (M1)
- 3) Nozzles cleaning inlet valve with built-in check valve (V2)
- 4) Drain valve (V3)
- 5) Inlet gate valve (V1)
- 6) Automatic air vent with built-in strainer
- 7) Insulation
- 8) Adjustable feet
- 9) Clapet check valve
- 10) Vacuum breaker valve
- 11) Plant pressure gauge
- 12) Strainer pressure gauge
- 13) Additives filling cap

Package content

- Strainer unit with magnets
- Installation and commissioning manual
- Pallet
- Packing case
- Pressure gauges to be fitted

Technical specifications of device and valves

Materials

Body-tubes and feet: stainless steel EN 10088-2 (AISI 304)
Internal filtering elements: Polyester

Inlet gate valves

Body: brass EN 12165 CW617N
Headwork: brass EN 12165 CW617N
Stem: brass EN 12164 CW614N
Body seal: Guarnital fibre
Stem seal: EPDM
Handwheel: plastic film laminated sheet steel

Drain valves

Body: brass EN 12165 CW617N
Stem: brass EN 12164 CW614N
Ball: brass EN 12165 CW617N, chrome plated
Ball seal: PTFE
Control stem seal: PTFE and EPDM O-Ring
Operating lever: Pressed steel with PVC covering

Nozzles cleaning inlet valve with built-in check valve

Body: brass EN 12165 CW617N
Ball: brass EN 12164 CW617N, chrome plated
Check valve: PA
Check valve spring: stainless steel
Check valve seal: EPDM
Control stem seals: PTFE

Circuit return valve with clapet retainer

Body: brass EN 12165 CW617N
Seals: EPDM

Performance

Medium: water, glycol solutions
Max. percentage of glycol: 50%
Maximum working pressure: 10 bar
Working temperature range: 5–85°C
Hydraulic characteristics: $K_v = 45 \text{ m}^3/\text{h}$
Water content: 50 l
Strainer mesh size \varnothing : 30 μm
Particle separation rating: down to 2 μm
Domestic water recommended inlet pressure: 3 – 5 bar

Connections

- in circuit inlet: 2" F
- in circuit outlet: 2" F
- filled for cleaning: 1" F
- drain: 1" F
- additive pouring cap: 1" F

Insulation

Material: PPE
Average thickness: 50 mm
Density: 45 kg/m^3
Working temperature range: 5–85°C
Thermal conductivity: 0.037 $\text{W}/(\text{m}\cdot\text{K})$ at 10°C

Sizing

The sizing of the dirt separator strainer must be performed considering the following values:

max. recommended flow rate: 20 m^3/h

Hydraulic characteristics

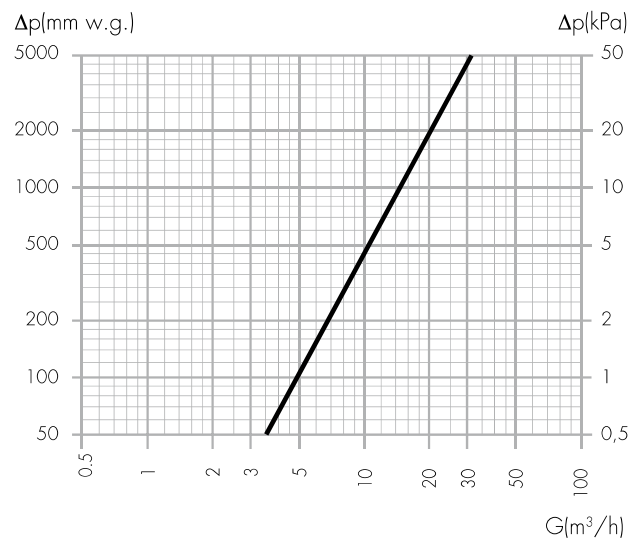

Connections	2"
$K_v(\text{m}^3/\text{h})$	45

Operating principle

This device flushes the system circuit medium by direct action through the direct action of passing through the specific filtering elements appropriately arranged inside the body. The specific filtering mesh allows the progressive removal of impurities that are deposited on the external surface of the strainers. Specific magnets attract the ferromagnetic particles.

This device operates according to different operating steps:

- filtration/ normal operation
- dirt discharge
- cleaning of filtering elements
- circuit filling and operating conditions reset

The opening status of the inlet and filling/drain valves must be managed manually in accordance with the selected process phase.

Depending on the type of system, the device can be combined with others for parallel operation.

The strainer clogging level can be approximately assessed by reading the pressure value shown on the two pressure gauges.

Installation in by pass with dedicated pump

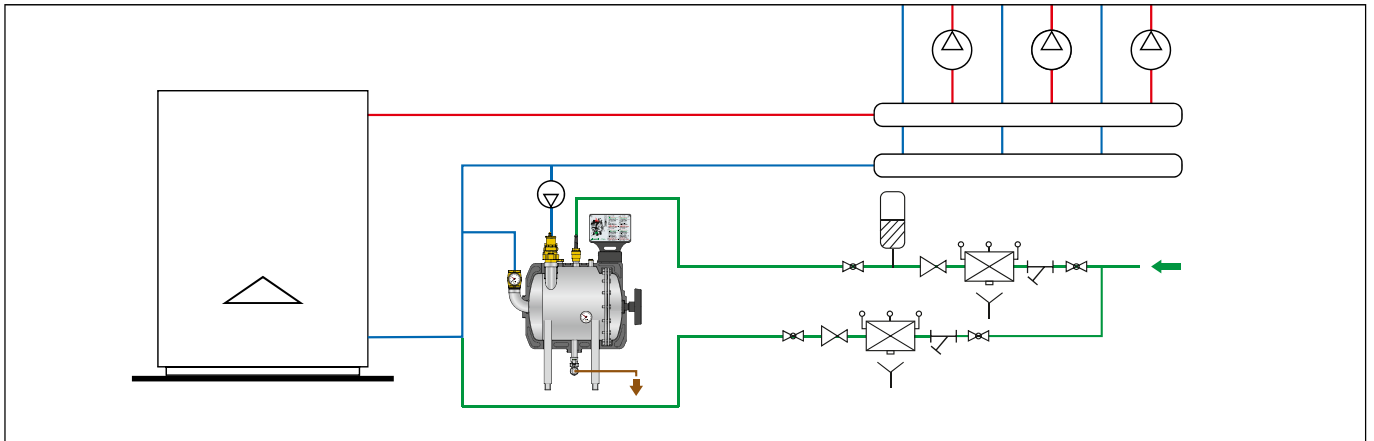

NOTE: circulator pump run/stop must be managed by an external control system.

Bypass type installation

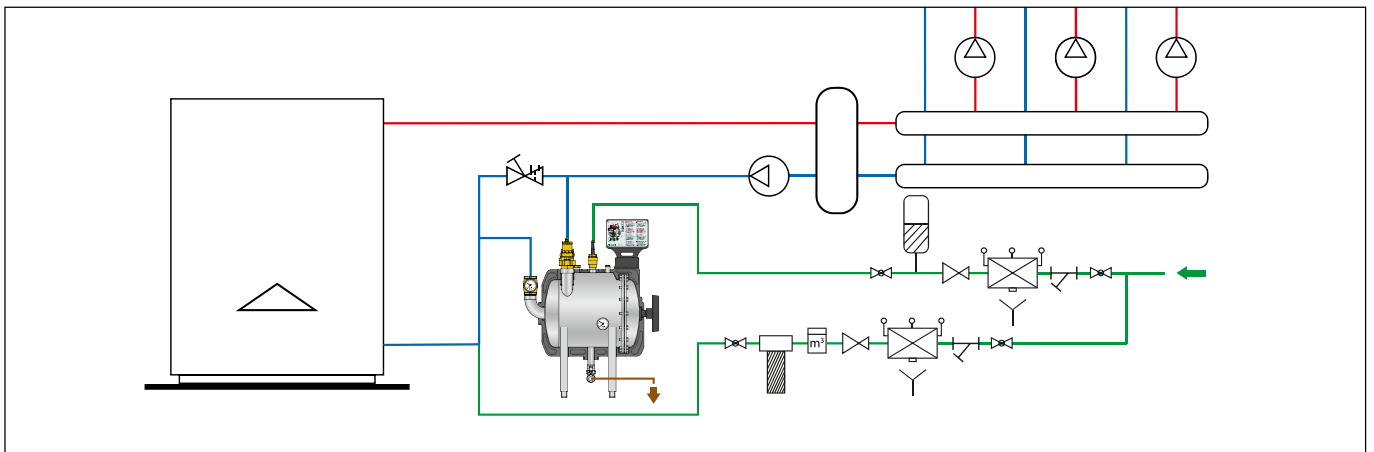

Installation with two strainers in parallel

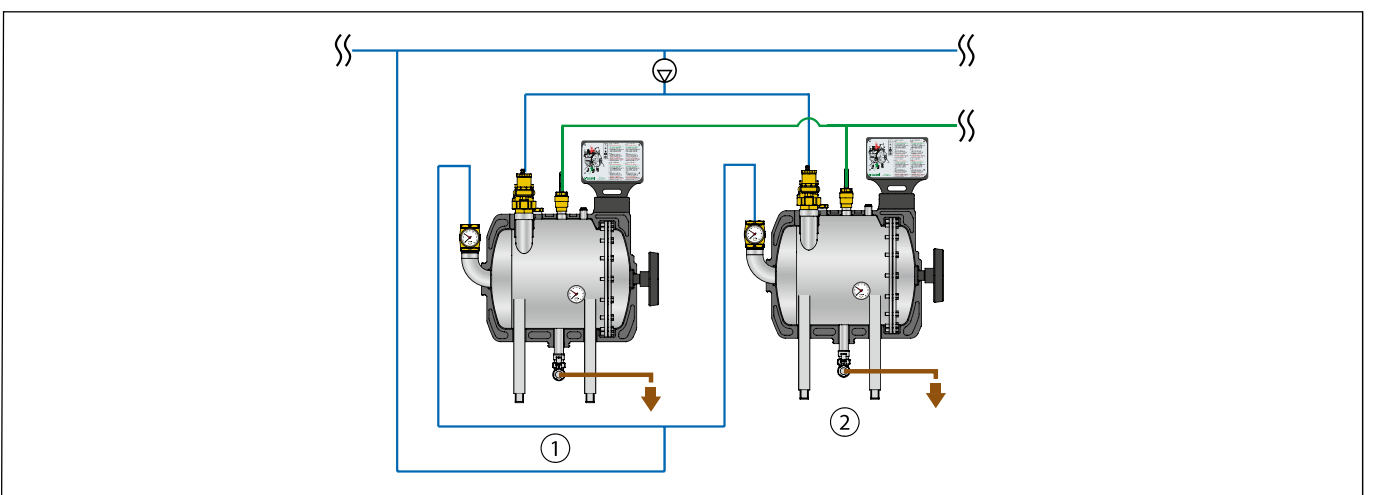

Filtration

During normal operation, the medium coming from the system enters in the strainer body through ball valve V1. The medium is forced to pass through the filtration discs, then it is conveyed into the central part until it comes out of the device through the clapet check valve.

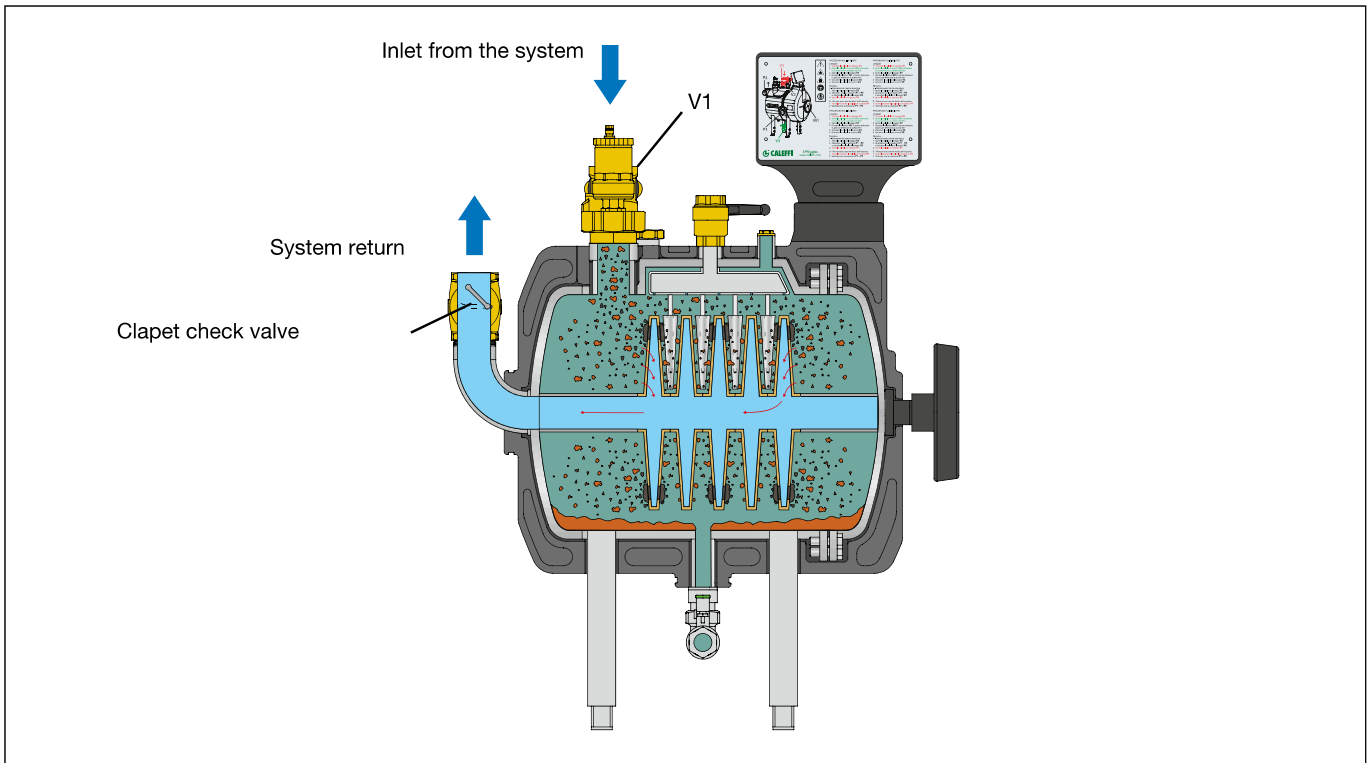

Cleaning of filtering elements



CAUTION! This operation must be carried out by qualified technical personnel because incorrect execution may lead to damage to the plant. Burns hazard, hot surfaces.

Close inlet valve V1 for the **first cleaning phase** (emptying). The clapet check valve prevents backflow from the installation. Open drain valve V3 located at the bottom of the device. When the vacuum breaker valve, present in the upper part of the strainer body, is opened it allows the progressive draining of the tank, causing the egress of part of the slurry present.

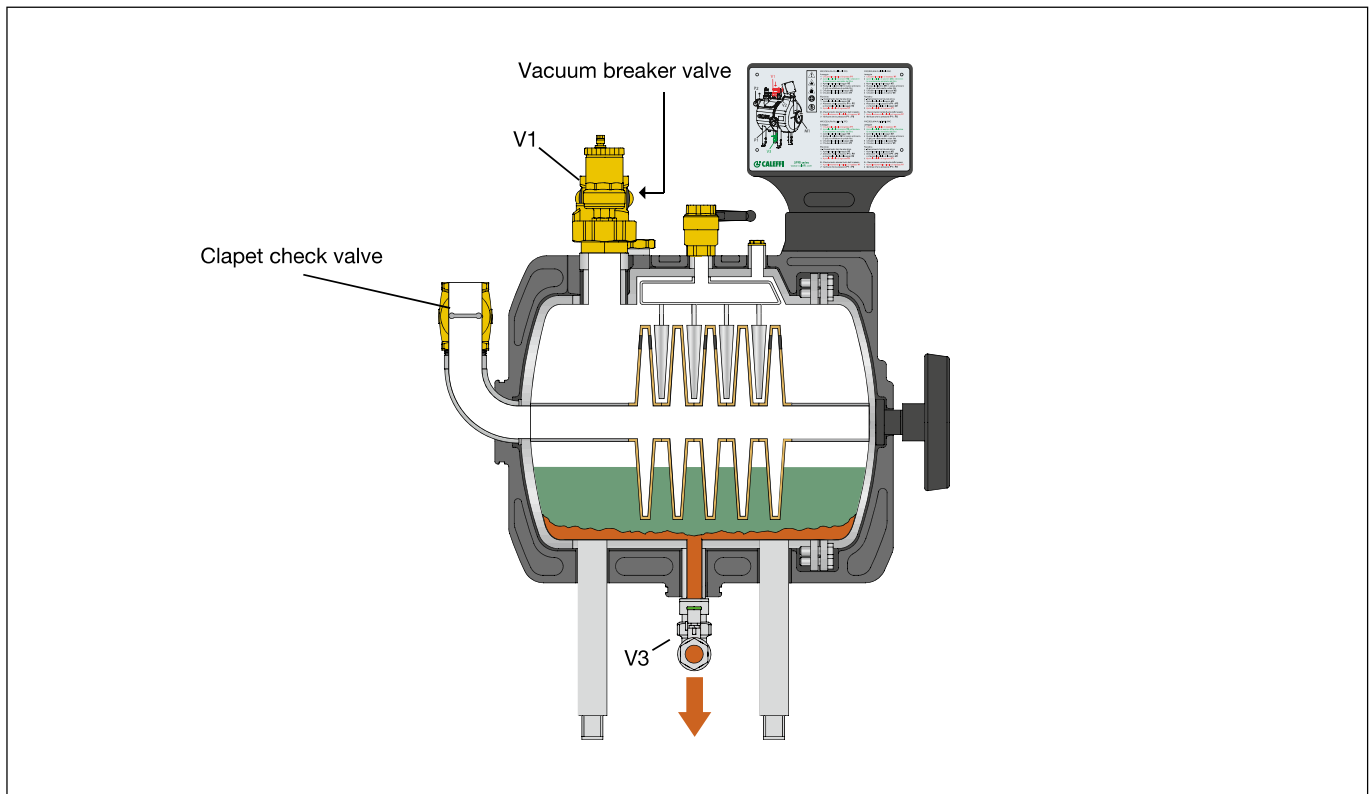

During the **second cleaning phase** (mechanical cleaning with water injection) open valve V2, and inject water from the domestic hot water circuit. For efficient washing, domestic hot water circuit pressure of between 3 and 5 bar must be guaranteed and it is mandatory to install a backflow prevention system to protect the water mains from possible contamination. Fit in compliance with statutory local legislation. Now turn the spindle on which the strainer discs are mounted by means of handwheel M1 (at least 5 counter-clockwise revolutions), thus allowing the fixed brushes to clean the disc surfaces and to clean the magnets. Operate the valves gradually, to prevent the situation wherein the device internal pressure is higher than the plant pressure. If this recommendation is disregarded the pressure in the plant would increase or air would be drawn into the circuit.

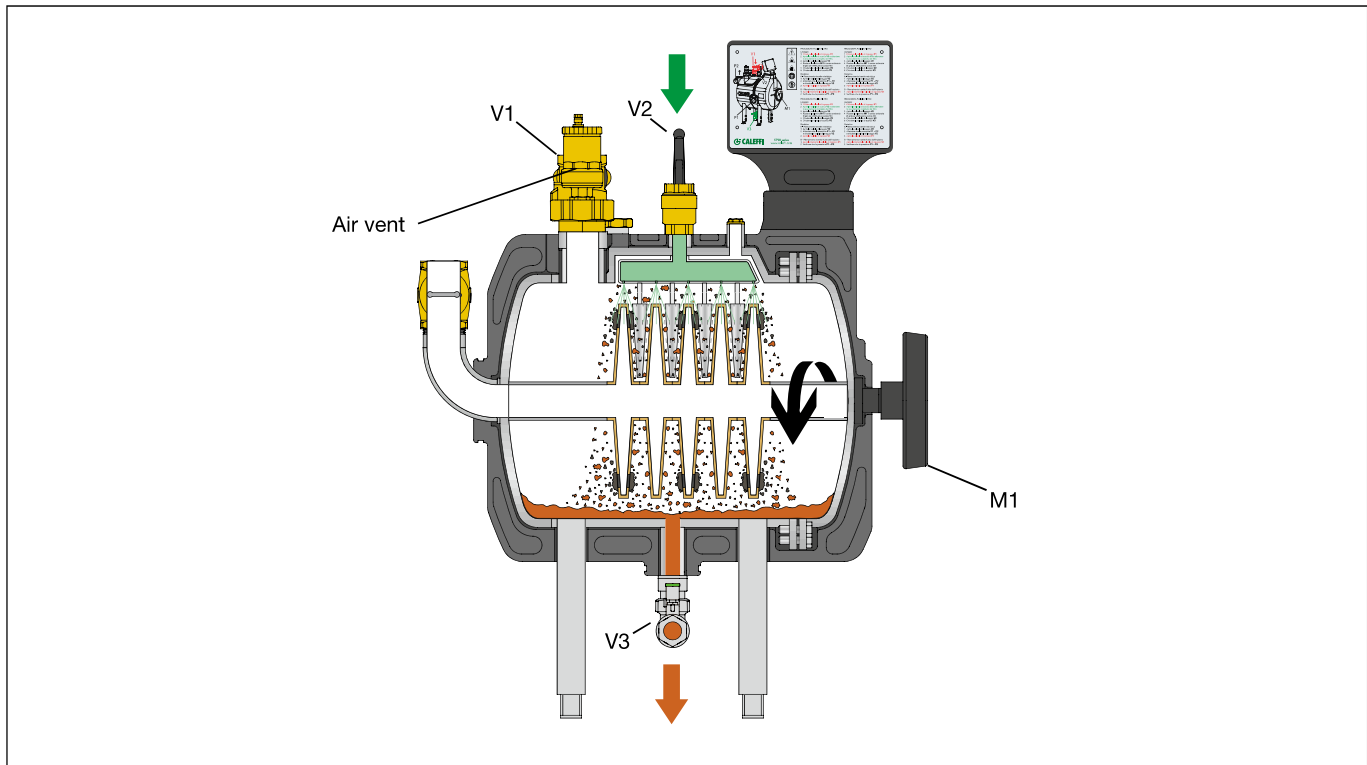

Circuit filling and operating conditions reset

Close valve V2. At the end of the cleaning phase the initial conditions are restored to proceed with normal filtration, after having closed drain valve V3. Strainer filling can occur in two ways: with domestic hot water via valve V2 or using the plant circuit via valve V1. This option is preferable when the water in the heating circuit is treated and contains additives. The filling action must be gradual until reaching the required pressure reading in the plant. During this phase the air vent valve operates in order to expel the air in the tank and allow optimal filling. The starting conditions are now restored. Check on the pressure gauges that P1 (strainer internal pressure) = P2 (plant pressure). Open valve V1.

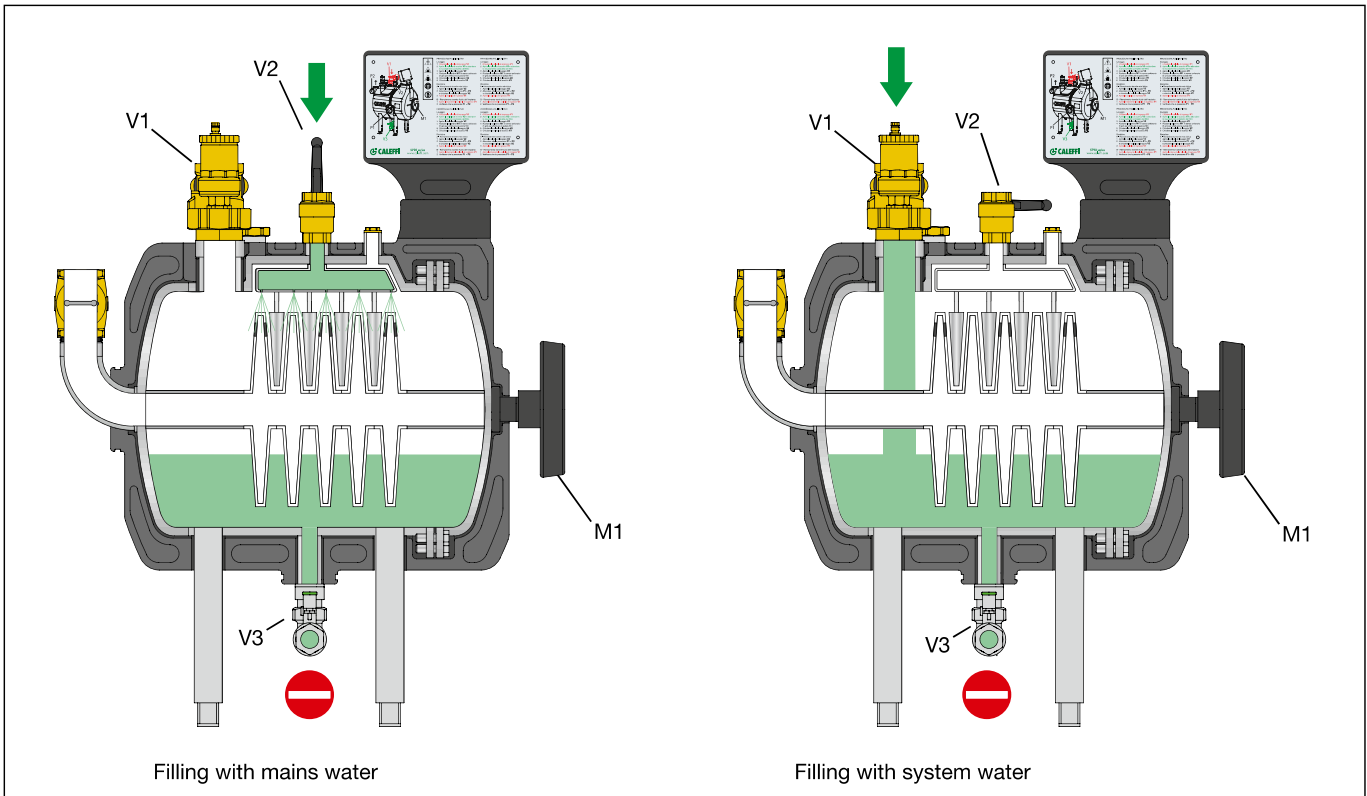

Intended use

The device is intended for use exclusively in heating systems containing water or water+glycol solutions up to a concentration of 50%. The device can be used in systems with maximum temperature of the medium of 85°C and maximum pressure of 10 bar. The minimum operating temperature of the medium is 5°C. In the case of applications with condensation phenomena the installer must provide a suitable and safe system to prevent condensate formation or disperse any condensation build-up, thus avoiding potential health risks or damage to property. The maximum ambient temperature is 50°C. The minimum ambient temperature during operation is 5°C, in the absence of condensation. The device must be assembled on the boiler return, with a suitably sized and calibrated bypass. Provide a passage area around the strainer of at least 50 cm and, at the rear, an area for extraordinary maintenance (strainer disassembling) of at least 100 cm:

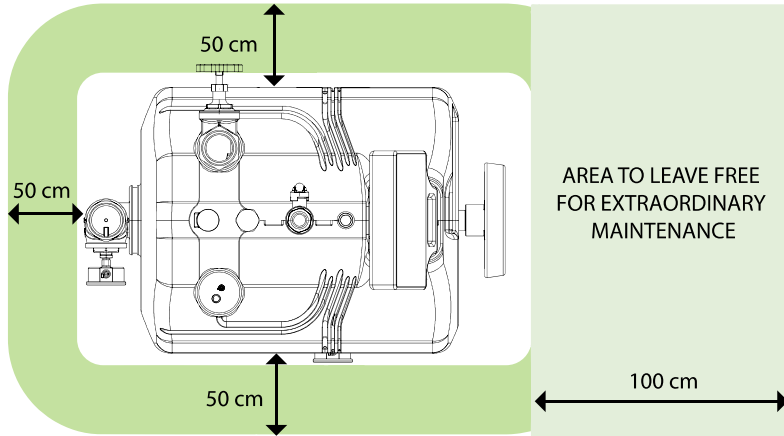

CAUTION: do not climb on, lean on, or sit on the device.



CAUTION: if the connection pipes are not properly insulated they could result in high temperature and cause burns and scalds. Provide a correct and safe insulation of all hot surfaces.

Packing, handling, transport

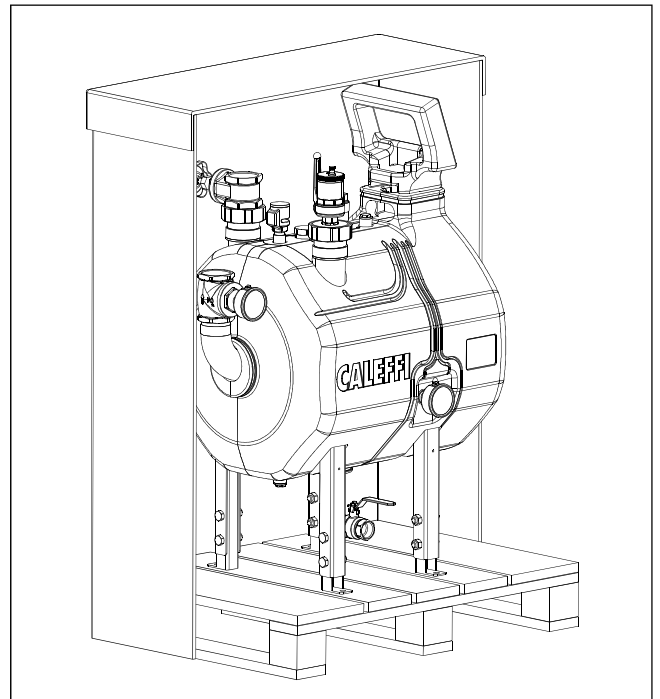
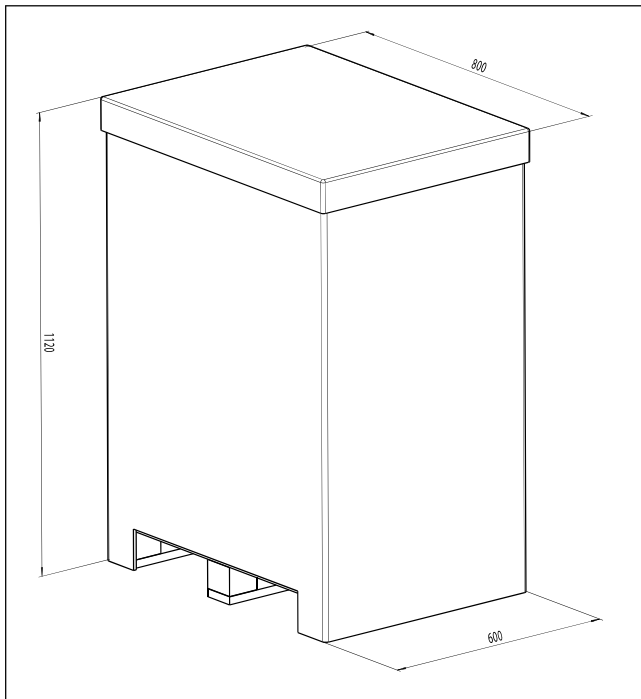

The strainer is shipped on a timber pallet to which it is securely attached. An external carton with cover protects the strainer in order to prevent damage that could occur during handling. The packaging is single-use and must be disposed of according to the indications provided for by the regulations in force.

Before any movement, make sure that the elements used for transport (trolleys, bridge cranes, nylon straps, ropes, etc.) are in perfect working order and can withstand loads of not less than 100 kg.

Move body and hands away when the strainer is lowered. Failure to follow these instructions could result in serious injury.

For no reason the personnel is authorized to pass under the load or near it, not even the signalman who will provide assistance to the movements.



The manufacturer declines any responsibility related to this phase that must be carried out by personnel specialized on handling industrial machinery (wheelers, boaters), equipped with the necessary personal protective equipment (overalls, safety shoes, work gloves, hard hat, goggles).

The movement must take place slowly, under suitable lighting conditions, with suitable free space in the installation area.



Caution! It is forbidden to handle the strainer with methods other than those indicated in the following document. Failure to comply with these conditions could cause serious injury to the user

Unpacking instructions

First open the cover and then the cardboard side, then remove the pallet with the strainer.

Storage



Do not overturn or tilt the package.
Multiple packages can not be stacked. Do not place any weight on top of the packaging.

Handling

It is advisable to move the strainer using mechanical devices (lift truck, crane, bridge crane, etc.) of adequate capacity.

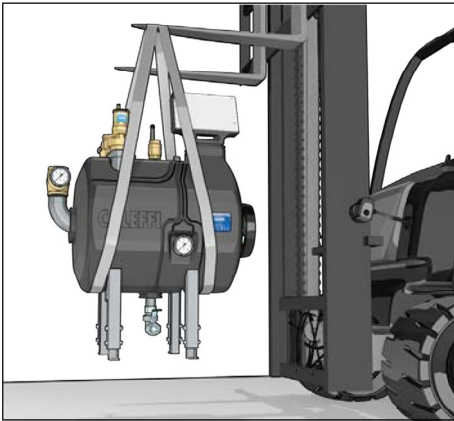

For lifting, use only code compliant straps positioned as shown in the diagrams alongside, taking care to keep them taut at all times to prevent them from slipping and taking care to keep the strainer parallel with the ground.

The device must be handled only if completely empty. The presence of liquids may cause them to leak or alter the centre of gravity during handling. These conditions can also cause serious damage to property or persons.

The device has an indicative empty weight of 50 kg: handling must be carried out according to safety regulations.

During the handling and temporary storage outside the wooden platform prepare all the necessary precautions to prevent the device from falling or overturning.

Disposal of packing materials

Follow the regulations in force for the disposal of the various components of the packaging.

Installation

When connecting water pipes, make sure that threaded connections are not overstressed mechanically. Over time, this could result in breakage, with water leaks causing damage and/or injury. Check that all connection fittings are watertight.



Water temperatures above 50°C can cause serious scalding. When installing, commissioning and servicing the device, take the necessary precautions so that these temperatures will not be hazardous for people. The device coupling with other system components must be made while taking the operational characteristics of both units into consideration. An incorrect coupling could compromise the operation of the device and/or system.

The strainer must be installed in a closed and dry place, protected from atmospheric agents. It must be positioned in a stable manner. The floor must be solid and well levelled. The installer must take care of the positioning of the strainer, maintaining adequate space around it to guarantee accessibility to every point of the system.

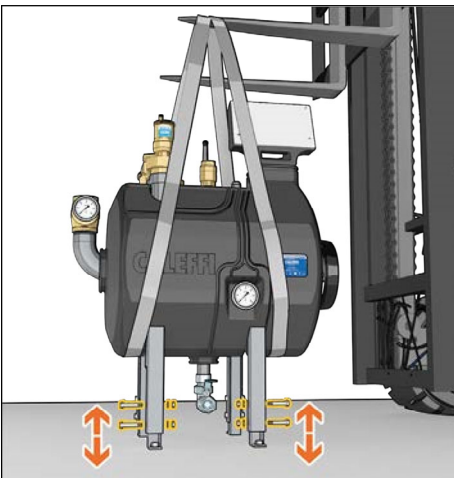

During installation it is possible to adjust the height of the device from the ground, by appropriately repositioning the fixing screws in the holes of the new desired height. This operation must be carried out lifting the device with suitable lifting devices to guarantee the safety levels necessary to prevent accidents and damage. Pay attention to correct fastening of the leg screws and tighten the nuts to a torque setting of 25 Nm.

The device must be installed in a horizontal position, firmly fastened to the floor by means of suitable fastening systems inserted in the holes (Ø 12 mm) set up at the base of the legs.

Failure to comply with the installation and start-up conditions could also cause a high level of risk for the user.



Caution! Do not use the handwheel to handle the device!

The device must be installed according to the diagrams given in this manual. The dirt separator must be installed on the return circuit, to intercept any impurities already present in the circuit, particularly when it is first started, before they can reach the boiler. The drain system must be operated in way that it does not prevent normal operation, avoiding counter pressure and must not endanger persons or property. It is possible to orient the drain in the most suitable direction, turning the ball drain valve and related fitting, after having loosened the captive nut. Take care not to subject the valve to bending stress. This operation must be carried out before commissioning, with a completely empty and pressure-free device.

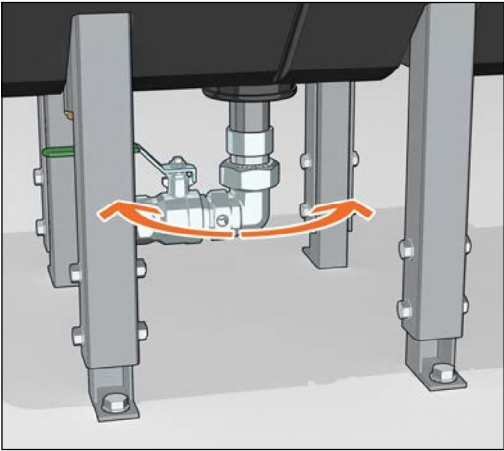

CAUTION: The device drain connection must be routed through a pipe or to a collection tank. Check full compliance with local legislation and regulations with regard to the drainage of filtration water to the sewer system, based on substances present in the water and in the dewatered slurry.

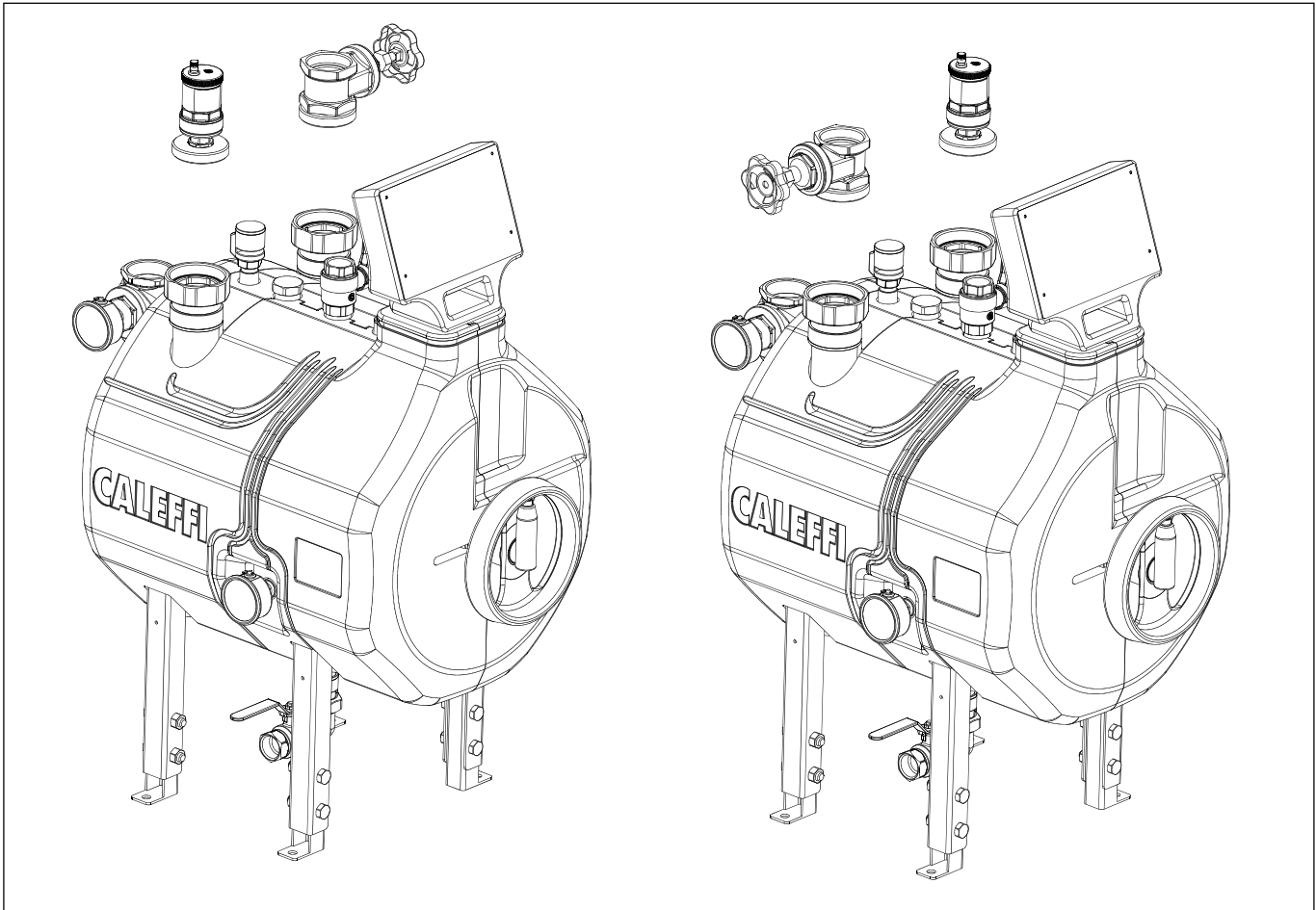

To allow easier installation it is possible to invert the position of the inlet valve V1 with the automatic air vent having the same 2 1/2" thread. This operation must be carried out during installation, with a pressure-free and completely empty strainer.

Dimensions

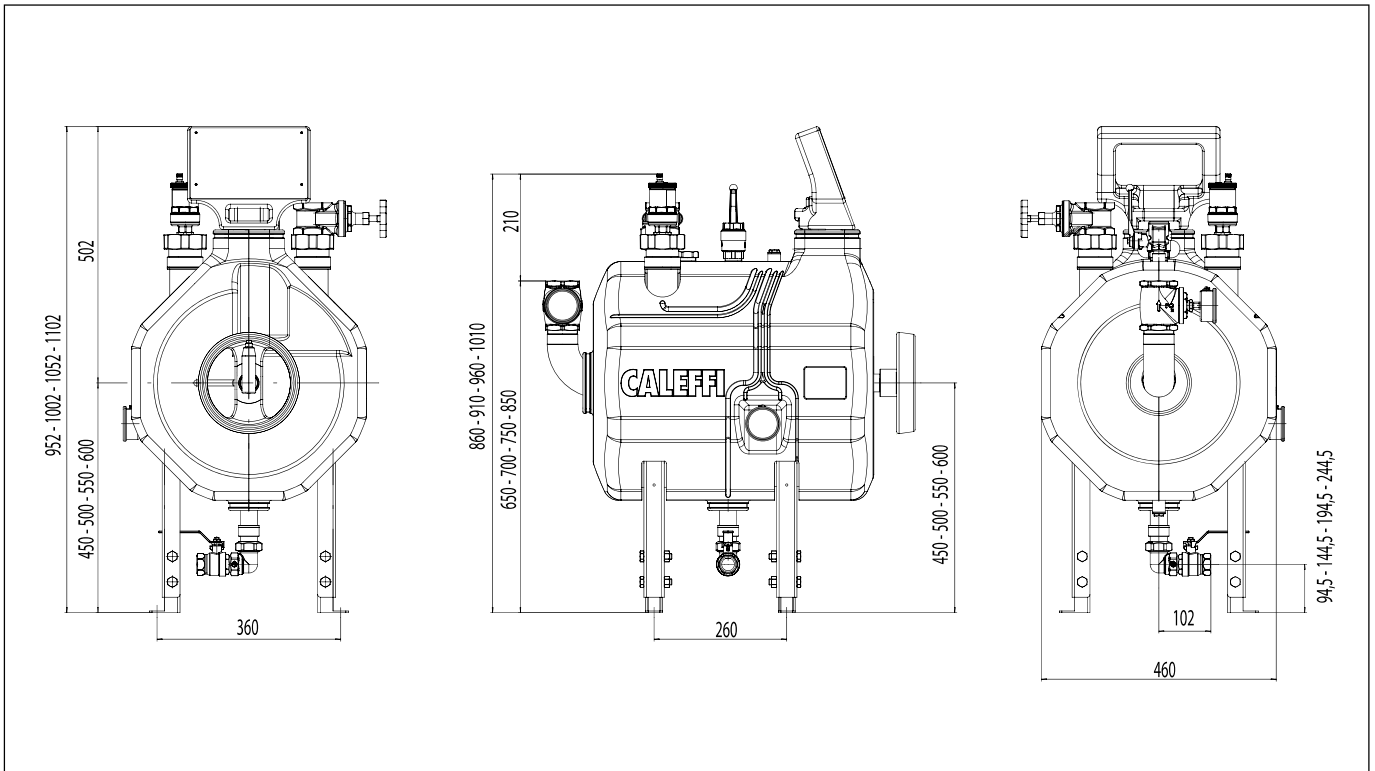

Cleaning

We recommend performing a cleaning cycle periodically and anyway at least once every 6 months.

Maintenance

The strainer is maintenance free. In the case of special problems, contact the Caleffi technical assistance network.



The device drains the liquid collected that can be at high temperatures (> 50°C), depending on the characteristics of the system in which it is installed: use appropriate precautions to comply with local regulations in force and concerning the water drain.

To avoid contamination of the potable water circuit and prevent backflow phenomena, fit a backflow preventer and a suitable strainer.

Limit the length of domestic hot water pipes used for cleaning: fit water hammer arresters or other devices to suppress the instantaneous overpressure events that can occur during operation.

The domestic water inlet line for strainer washing may be subject to thermal overpressure: install suitable safety relief valves or expansion vessels.



The domestic hot water inlet line may be subject to freezing risk. Provide suitable insulation or systems to avoid ice formation.

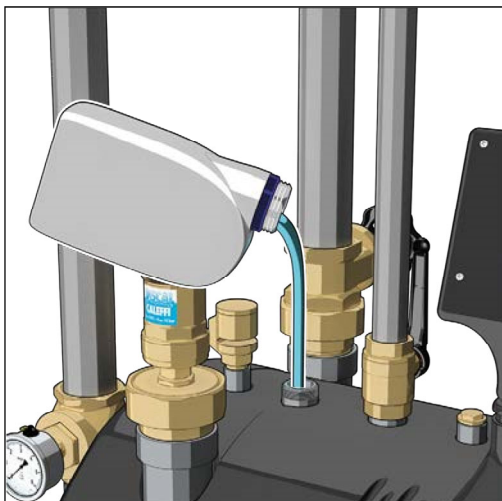

Use of additives

You can inject additives into the plant medium using cap no. 1 at the top of the strainer. Carefully check the cap watertight closing, in order to prevent leakage or flooding. Perform the operation when the strainer is empty, unpressurised, and with valves V1, V2, V3 all closed.

Maximum additive quantity per filling cycle: 40l



The additives must be in liquid form and they must be added with care and slowly to prevent accidental spillages.

Check the compatibility between the type of additives used and the dirt separator strainer materials. Any incompatibilities can result in serious damage to the strainer, injury to persons or damage to property. Avoid contact with skin and eyes. Avoid inhalation, use personal protective equipment. Do not disperse in the environment. Refer to the safety data sheet and the technical documentation of the product.

The operations must be performed in compliance with statutory legislation, exclusively by qualified personnel.

Commissioning

To clean the strainer, follow the instructions shown in the label below.

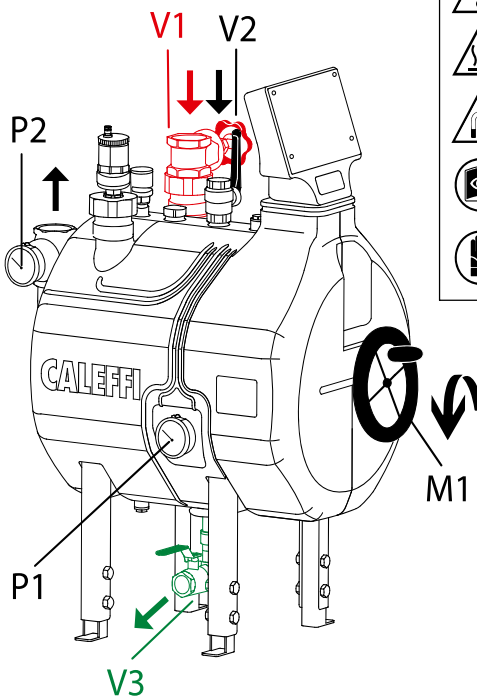

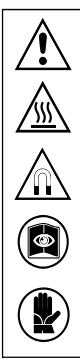

PROCEDURA PULIZIA FILTRO

Lavaggio

- 1 **Chiudere la valvola di ingresso V1**
- 2 **Aprire la valvola di scarico V3 e attendere lo svuotamento completo del filtro**
- 3 **Aprire la valvola di lavaggio V2 (3 bar < p ingresso < 5 bar)**
- 4 **Ruotare il volantino M1 in senso antiorario (5 giri) per effettuare la pulizia filtri**
- 5 **Chiudere la valvola di lavaggio V2**
- 6 **Chiudere la valvola di scarico V3**

Ripristino

A - Riempimento tramite rete idrica

- 1 **Aprire lentamente la valvola di lavaggio V2**
- 2 **Attendere che la pressione P1 = P2 e chiudere la valvola di lavaggio V2**
- 3 **Aprire la valvola di ingresso V1**

B - Riempimento tramite fluido dell'impianto

- 1 **Aprire lentamente la valvola di ingresso V1**
- 2 **Verificare che la pressione P1 = P2**

PROCÉDURE DE NETTOYAGE DU FILTRE

Lavage

- 1 **Fermer la vanne d'entrée V1**
- 2 **Ouvrir la vanne de purge V3 et attendre que le filtre soit totalement vidé**
- 3 **Ouvrir la vanne de lavage V2 (3 bar < p entrée < 5 bar)**
- 4 **Tourner le volant M1 dans le sens contraire des aiguilles d'une montre (5 tours) pour nettoyer les filtres**
- 5 **Fermer la vanne de lavage V2**
- 6 **Fermer la vanne de purge V3**

Rétablissement

A - Remplissage par le réseau de distribution d'eau

- 1 **Ouvrir lentement la vanne de lavage V2**
- 2 **Attendre que la pression P1 = P2, puis fermer la vanne de lavage V2**
- 3 **Ouvrir la vanne d'entrée V1**

B - Remplissage de l'installation avec du fluide

- 1 **Ouvrir lentement la vanne d'entrée V1**
- 2 **Vérifier que la pression P1 = P2**

STRAINER CLEANING PROCEDURE

Washing

- 1 **Close the inlet valve V1**
- 2 **Open the drain valve V3 and wait for the strainer to empty completely**
- 3 **Open the washing valve V2 (3 bar < p inlet < 5 bar)**
- 4 **Turn the handwheel M1 clockwise (5 turns) to clean the strainers**
- 5 **Close the washing valve V2**
- 6 **Close the drain valve V3**

Restoring

A - Filling from the mains supply

- 1 **Slowly open the washing valve V2**
- 2 **Wait until the pressure P1 = P2 and then close the washing valve V2**
- 3 **Open the inlet valve V1**

B - Filling with the plant medium

- 1 **Slowly open the inlet valve V1**
- 2 **Check that the pressure P1 = P2**

FILTERRÜCKSPÜLUNG

Spülen

- 1 **Das Eingangsventil V1 schließen**
- 2 **Das Ablassventil V3 öffnen und warten, bis der Filter vollständig entleert ist**
- 3 **Das Spülventil V2 öffnen (3 bar < p Eingang < 5 bar)**
- 4 **Handrad M1 gegen den Uhrzeigersinn (5 Umdrehungen) drehen, um die Filter zu reinigen**
- 5 **Das Spülventil V2 schließen**
- 6 **Das Ablassventil V3 schließen**

Instandsetzung

A - Befüllung über Wasserleitung

- 1 **Das Spülventil V2 langsam öffnen**
- 2 **Warten bis Druck P1 = P2 und Spülventil V2 schließen**
- 3 **Das Eingangsventil V1 öffnen**

B - Befüllen mit Systemflüssigkeit

- 1 **Das Eingangsventil V1 langsam öffnen**
- 2 **Überprüfen, dass der Druck P1 = P2**

H0005251



NOTE To guarantee correct operation of the strainer, check that the air vent cap has been loosened sufficiently (1/2 turn from completely closed).



Commissioning must be carried out according to the regulations in force by qualified personnel.

Check that the cold water supply pressures are within the operating limits of the device. Check that the temperature of the hot drain water has a value complying with the regulations in force.

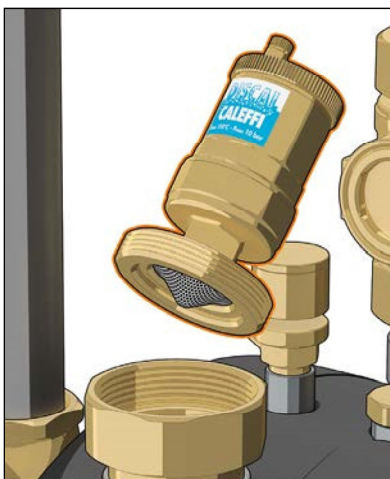

Automatic air vent strainer cleaning

For periodic cleaning of the automatic air vent, check that the strainer is not pressurised and access it by undoing the 2 1/2" captive nut using the appropriate wrench. Clean the strainer washing it under running water. Refit the strainer, checking the condition of the O-Ring; replace the O-Ring if necessary. Tighten the nut, checking for leakage or seepage.

Spare parts

Consult the drawing of the spare parts with the associated table showing the code and description of the individual parts supplied as spares

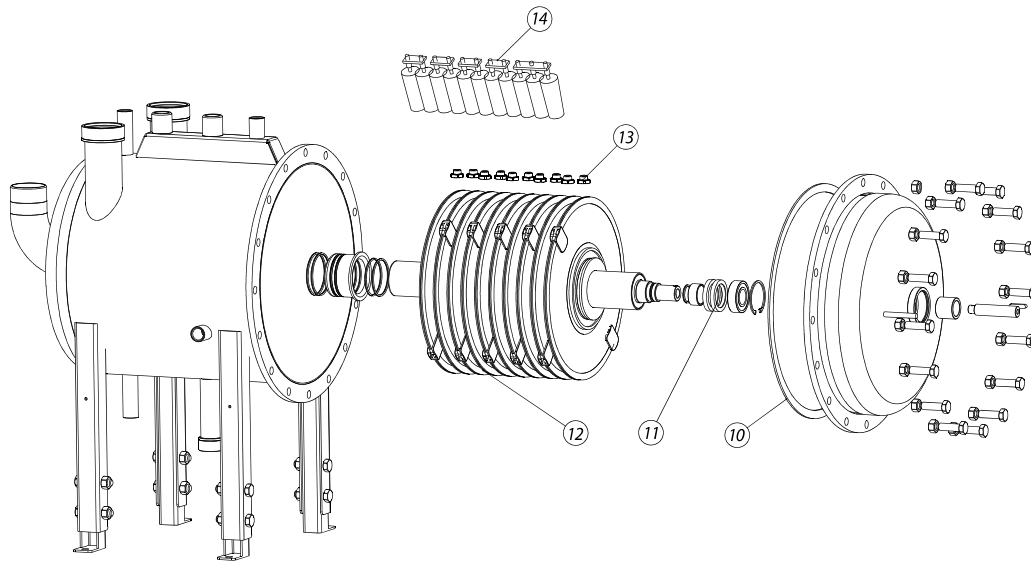

Ref.	Description	Code
1	Replacement strainers movement handwheel	F0000982
2	Ball valve with built-in check valve	327600
3	Replacement gate valve	F0000984
4	Replacement vacuum breaker valve d.1/2"	F0000949
5	DISCAL deaerator with housing 1/2" F	551004
6	Replacement O-ring 62 x 3 ep-perox 70° sh	R57314
7	Replacement clapet check valve d.2 "F	F0000953
8	0-10P. pressure gauge centr. Ø 1/4"	R59311
9	Replacement ball valve Ø 1 "MF" green lever	F0000983
10	Replacement seal for 579 series flange	F0000956
11	Replacement shaft sealing unit 579 series	F0000959
12	Replacement 579 series filtering unit	F0000960
13	Replacement Ø1/4" gas nozzle with O-ring	F0000957
14	Strainer cleaning brushes x 579 spare part	F0000958

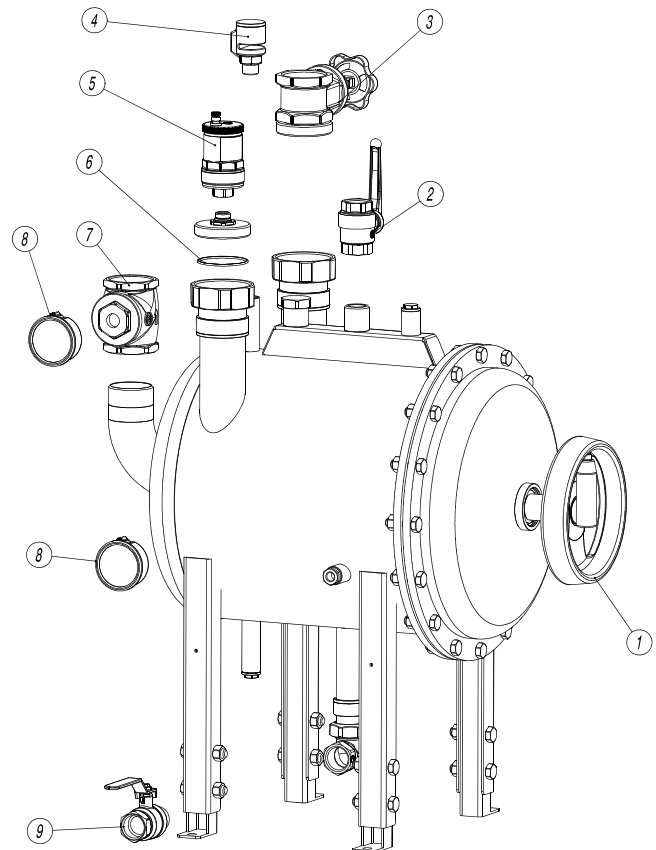

LEAVE THIS MANUAL AS A REFERENCE GUIDE FOR THE USER

